

s.r.l. GORLA
MORSETTERIE
MILANO

MORSETTI DIRITTI
PER CORDA A1 A COMPRESSIONE
E PIASTRA A 4 FORI A1

DIS. N. 98/AA/X

Rev.2 del 09.03.20

UFFICIO TECNICO

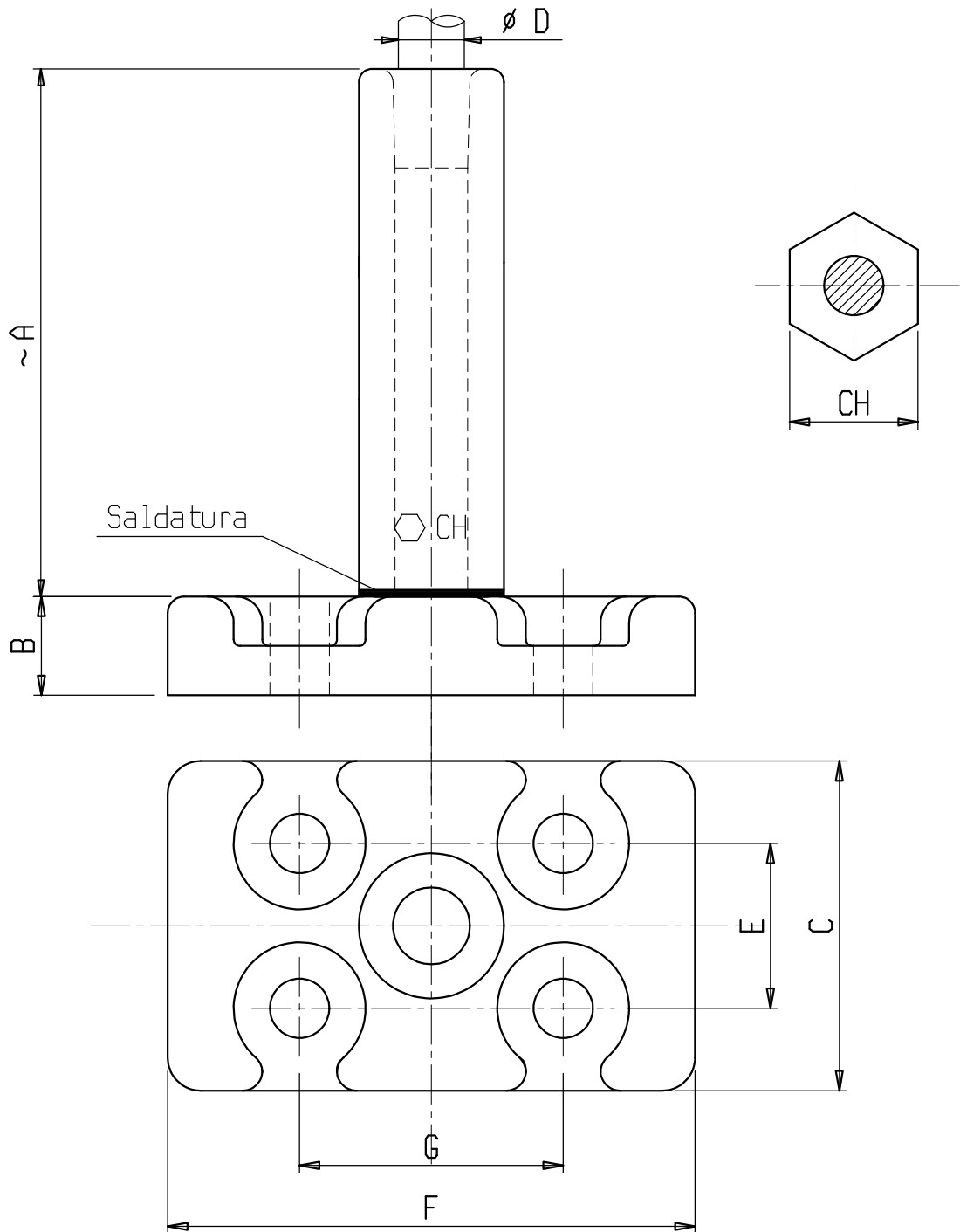

Materiale: lega di Alluminio

X	ϕ COND.	A	B	C	E	F	G	CH
	D							
C 6029 17-19	17-19	160	30	100	50	160	80	34
C 6029 19-22	19-22	160	30	100	50	160	80	34
C 6920AAP	27.5-30.5	160	30	100	50	160	80	44
C 6029	35.5-37.5	160	30	100	50	160	80	54