

s.r.l. GORLA
MORSETTERIE
MILANO

GIUNZIONE DIRITTA
PER CORDA A1 E PIATTO A1

DIS. N. 15/AA/X

Rev.4 del 03.03.20

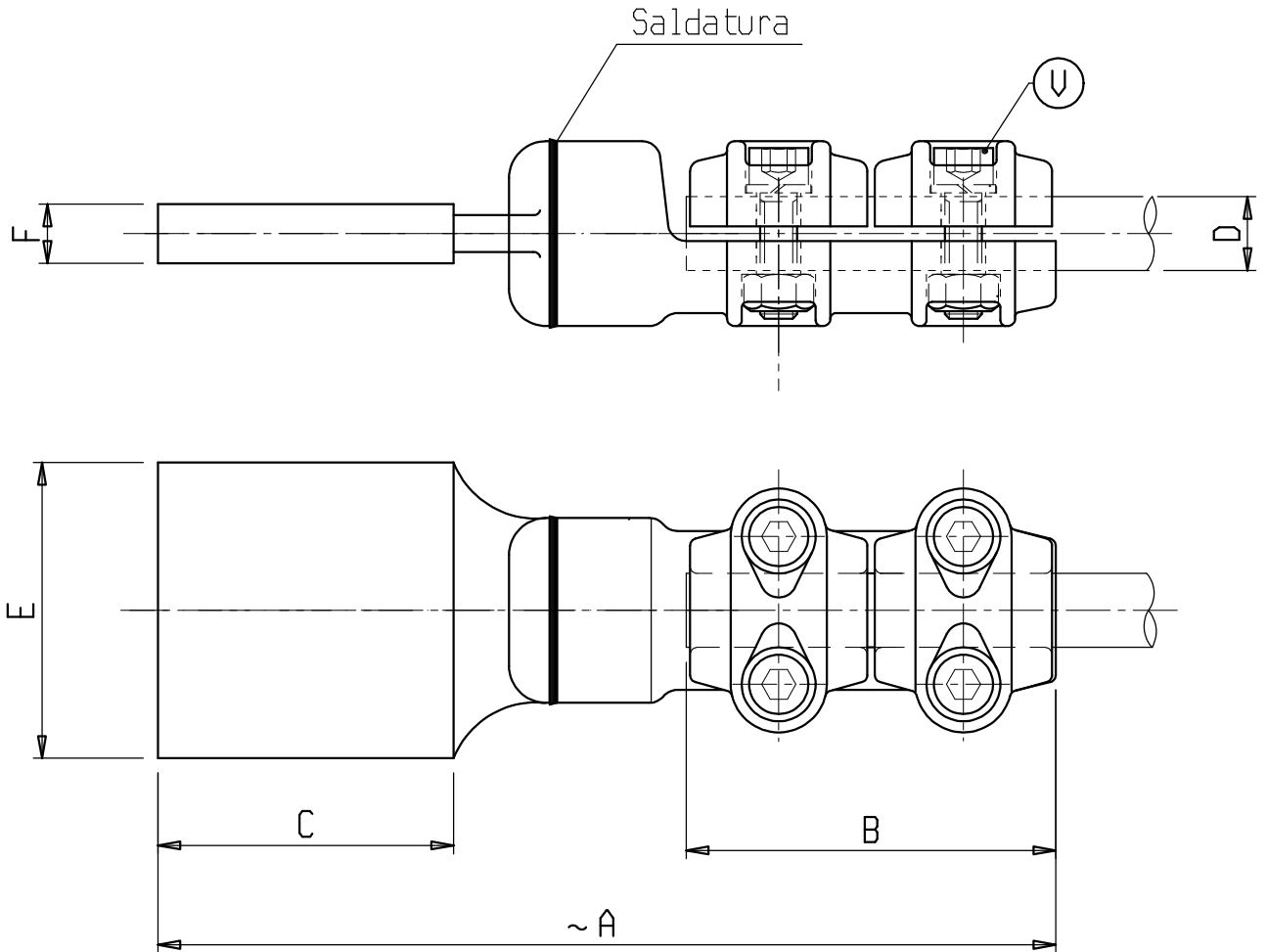

Materiale: lega di Alluminio
Bulloneria: Acciaio inossidabile

X	∅ COND.	A	B	C	E	F	U	X	∅ COND.	A	B	C	E	F	U
	D								D						
C 6291AAP	12-20	230	100	60	60	6	M10	C 0380-120AA	32-36	290	100	120	100	10	M10
C 6529AAP	12-20	250	100	80	80	8	M10	C 0376AA	32-36	275	100	105	185	14	M10
C 6553AA	12-20	270	100	100	100	10	M10	C 6592AA	36-40	250	100	80	80	10	M10
C 1651AA	20-25	290	100	120	100	10	M10	C 1597AA	36-40	270	100	100	100	10	M10
C 6577AA	25-32	270	100	100	100	10	M10	C 1597-120AA	36-40	290	100	120	100	10	M10
C 6577-120AA	25-32	290	100	120	100	10	M10								
C 0380AA	32-36	270	100	100	100	10	M10								