

s.r.l. GORLA

MORSETTERIE  
MILANO

TECHNICAL OFFICE

# T CONNECTOR

FOR A1 CONDUCTOR WITH ARMOUR RODS  
RUN AND TAP COMPRESSION TYPE

DRG. N. 89/AA/X

Rev.5 dated 24.07.15

Page 1/2

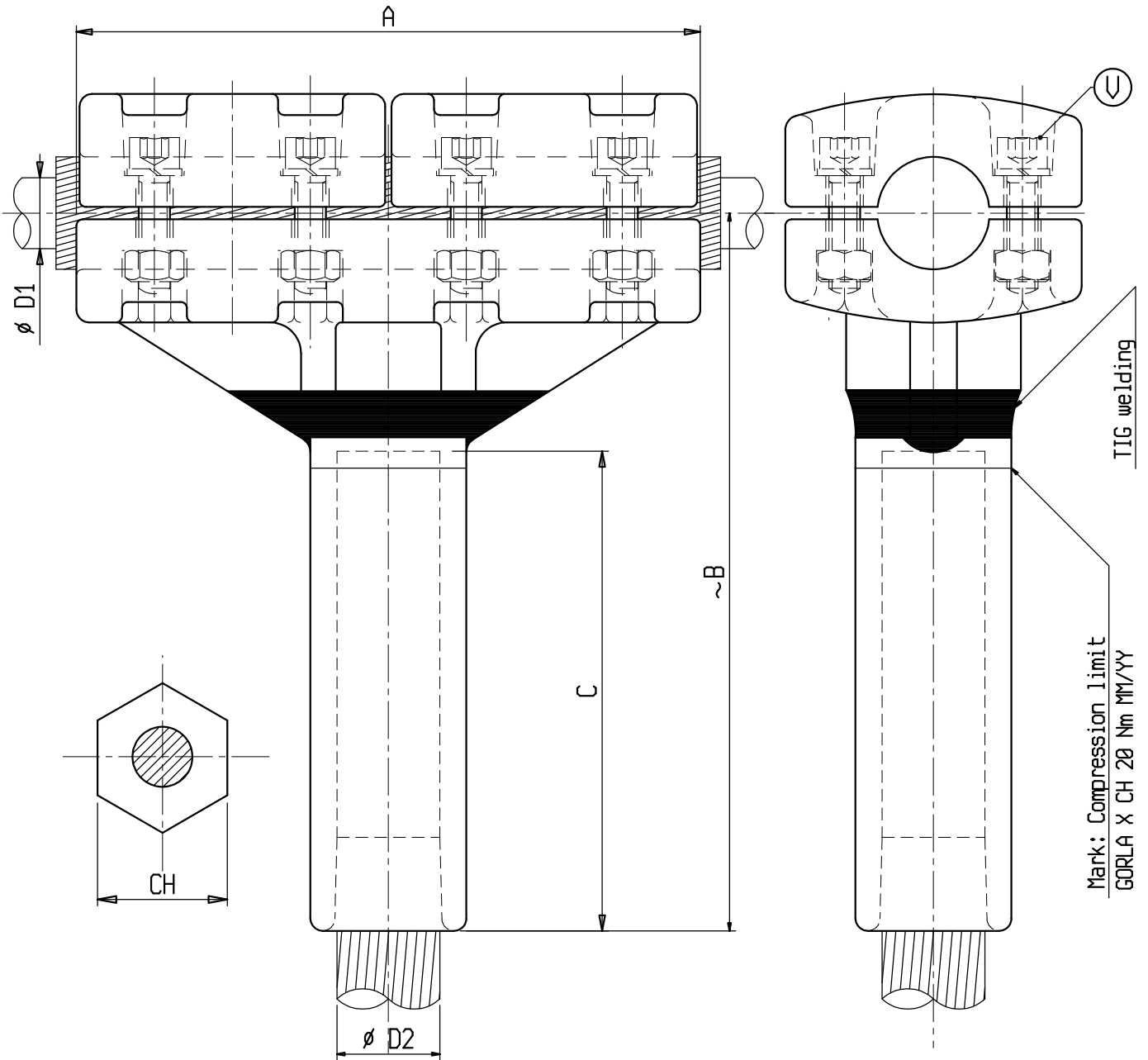

Material: Aluminium alloy

Bolts: Stainless steel

