

s.r.l. GORLA
MORSETTERIE
MILANO

UFFICIO TECNICO

RACCORDI FORCELLA
ORBITA

DIS. N. AT15/X

Rev.2 del 28.02.14

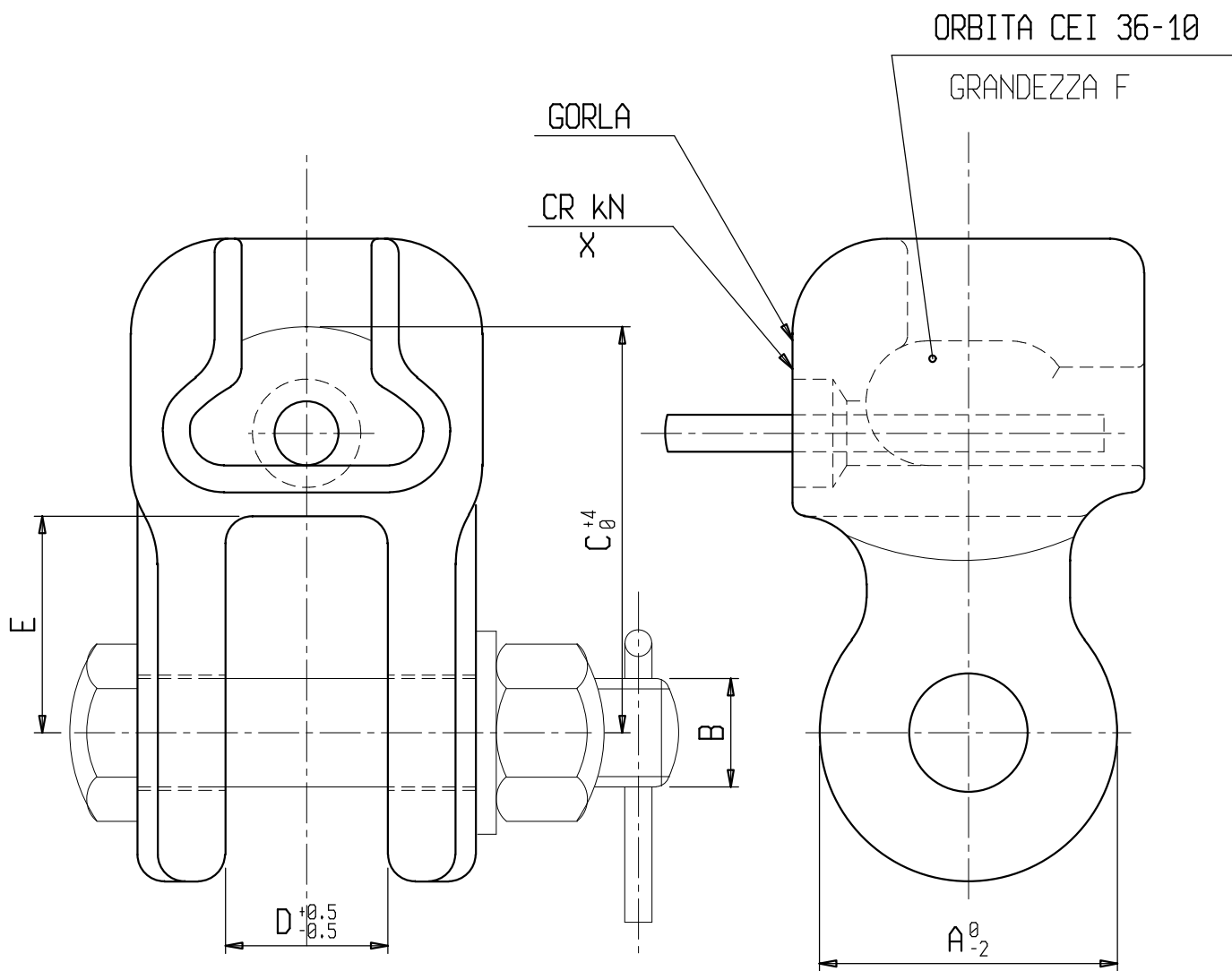

Materiale: Acciaio zincato a caldo. Copiglia in acciaio inox

| X | A | B | C | D | E | F | CR [kN] |
|------------|----|------|------|----|----|----|---------|
| LS 3118 | 44 | M 16 | 60 | 24 | 32 | 16 | 120 |
| LS 3118HE | 44 | M 16 | 60 | 21 | 32 | 16 | 100 |
| LS 4657 | 48 | M 20 | 75 | 24 | 38 | 20 | 210 |
| LS 0295M20 | 55 | M 20 | 95.5 | 24 | 52 | 24 | 300 |
| LS 0295 | 55 | M 27 | 95.5 | 24 | 52 | 24 | 300 |