

Material. E1, 5, 6 and 7: hot dip galvanized steel
 C1, M and P1: aluminium alloy
 1, 2, 3 and 4: hot dip galvanized or stainless steel
 8: stainless steel

s.r.l. GORLA
 MORSETTERIE
 MILANO
 TECHNICAL OFFICE

COMPRESSION DEAD-END
 CLAMPS
 FOR ACSR CONDUCTORS
 WITH 2 BOLTS

Rev.3 dated 15.11.16
 DRG. N. AT01-2/X

s.r.l. GORLA
MORSETTERIE
MILANO

TECHNICAL OFFICE

COMPRESSION DEAD-END
CLAMPS
FOR ACSR CONDUCTORS
WITH 2 BOLTS

DRG. N. AT01-2/X

Rev. 15 dated 19.02.19

X	Ø COND.		W1	W2	CR [kN]	E1	P1	M	C1
	D1	D2							
LS6636945	9,45	9,45			16,40	LS5220945	LS0237F	M1/LS6641945	LS6639945
LS6636	13,30	13,30			41	LS5220AA4	LS0237F	M1/LS6641	LS6639
LS6636132	13,32	13,32			35	LS5220AA0	LS0237F	M1/LS6641132	LS66391
LS66361425	14,25	14,25			40	LS52201425	LS0237F	M1/LS6641425	LS52181425
LS66361431	14,31	14,31			35	LS52201431	LS0237F	M1/LS6641431	LS66391431
LS5216147SP	14,70	14,70			95	LS5220147SP	LS52191S	LS5217147SP	LS5218147SP
LS5216147	14,70	14,70			49,60	LS5220147	LS521925-1	M1/LS5217147	LS5218147
LS6635155	15,50	15,50			46	LS5220AA10	LS0237F	LS6640155	LS6638155
LS6635157	15,75	15,75			57	LS5220AA9	LS0237F	M1/LS6640157	LS6638
LS6635157-1	15,75	15,75			57	LS5220157-1	LS0237F	M1/LS6640157-1	LS6638157-1
LS6635	15,85	15,85			49	LS5220AA3	LS0237F	M1/LS6640	LS66381
LS6635-22,8	15,85	22,80			49	LS5220AA3	LS0237	M1/LS6640-22,8	LS5218
LS521617	17,00	17,00			57	LS5220AA14	LS5219	M1/LS521717	LS521817
LS5216175	17,50	17,50			70	LS5220A10	LS5219	M1/LS5217175	LS52181
LS6635177	17,74	17,74			60	LS5220AA6	LS52191S	M1/LS5217177	LS521812
LS663517734	17,74	17,74			60	LS5220AA6	LS5219	M1/LS521717734	LS521817734
LS52161813CD	18,13	18,13	WOLF	WOLF	69	LS5220AA15	LS0237F	M1/LS52161813BI	LS6639200bis
LS52161883	18,83	18,83			74,5	LS52201883	LS5219	M1/LS52171883	LS82181883
LS5216190	19,02	19,02			69	LS5220AA1	LS5219	M1/LS52171	LS52188
LS5216192	19,02	22,80			69	LS5220AA1	LS5219	M1/LS5217192	LS5218
LS6869	19,38	19,38			71	LS6872	LS52191S	M1/LS6870	LS6871
LS52161938	19,38	19,38			71	LS52201938	LS5219	M1/LS52171938	LS52181938
LS6869196	19,60	19,60			86	LS5220AA8	LS52191S	M1/LS6870196	LS68712
LS5216196	19,60	19,60			86	LS5220AA8	LS5219	M1/LS5217196	LS52182
LS52162025	20,25	20,25			74	LS5220A13	LS5219	M1/LS52172025	LS521813
LS5216202	20,27	20,27			78	LS5220A11	LS5219	M1/LS5217202	LS52184
LS5216207	20,70	20,70			76,5	LS5220207	LS5219	M1/LS5217207	LS5218207
LS521621	21,00	21,00			99	LS5220AA7	LS5219	M1/LS521721	LS52185
LS5216216	21,66	21,66			89	LS5220AA5	LS5219	M1/LS5217216	LS52186
LS5216218	21,80	21,80			90	LS5220A12	LS5219	M1/LS5217218	LS52189
LS5216218-1	21,80	21,80			103	LS5220A12-1	LS5219	M1/LS5217218-1	LS52189
LS5216224	22,40	22,40			109	LS5220AA2	LS5219	M1/LS5217224	LS52187
LS5216225	22,50	22,50			90	LS5220225	LS5219	M1/LS5217225	LS5218225
LS5216	22,80	22,80			98	LS5220	LS5219	M1/LS5217	LS5218
LS5216248	24,80	24,80			104	LS52201	LS5219	M1/LS5217A4	LS52183
LS52162484S	24,84	24,84			108	LS52202	LS5219	M10/LS52172484S	LS52182484S

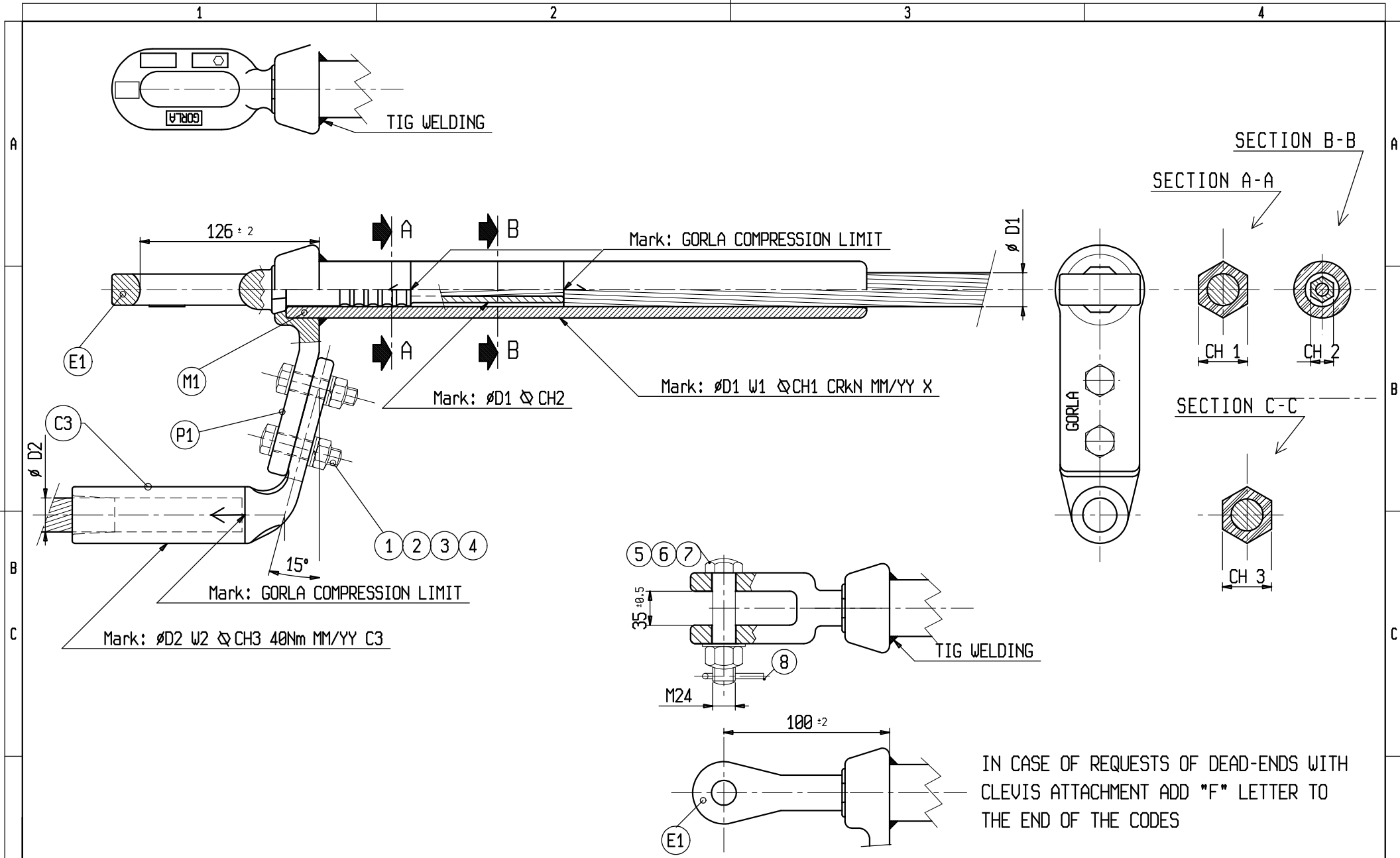

Material. E1, 5, 6 and 7: hot dip galvanized steel
 C3, M1 e P1: aluminium alloy
 1, 2, 3 e 4: hot dip galvanised or stainless steel
 8: stainless steel

s.r.l. GORLA
 MORSETTERIE
 MILANO
 TECHNICAL OFFICE

COMPRESSION DEAD-END
 CLAMPS
 FOR ACSR CONDUCTORS
 WITH 2 BOLTS

Rev. 3 del 15.11.16
 DRG. N. AT01-2-D/X

IN CASE OF REQUESTS OF DEAD-ENDS WITH
 CLEVIS ATTACHMENT ADD "F" LETTER TO
 THE END OF THE CODES

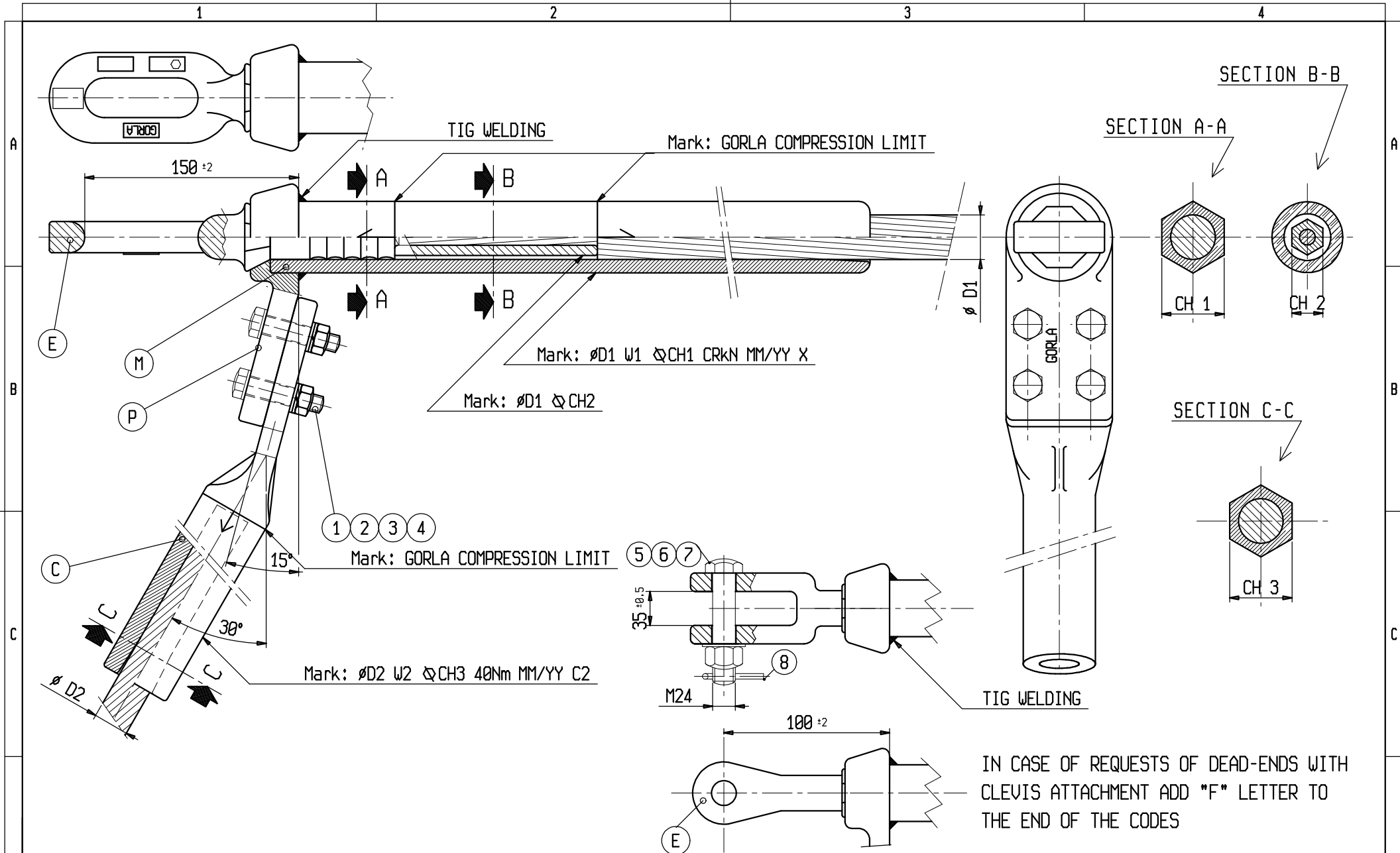

Material. E, 5, 6 and 7: hot dip galvanized steel
 C, M and P: aluminium alloy
 1, 2, 3 and 4: hot dip galvanized or stainless steel
 8: stainless steel

s.r.l. GORLA
 MORSETTERIE
 MILANO
 TECHNICAL OFFICE

COMPRESSION DEAD-END
 CLAMPS
 FOR ACSR CONDUCTORS
 WITH 4 BOLTS

Pag. 1/3
 Rev.7 dated 15.11.16
 DRG. N. AT01-4/X

s.r.l. GORLA
MORSETTERIE
MILANO

TECHNICAL OFFICE

COMPRESSION DEAD-END
CLAMPS
FOR ACSR CONDUCTORS
WITH 4 BOLTS

DRG. N. AT01-4/X

Rev. 29 dated 30.05.21

Pag. 2/3

X	∅ COND.		W1	W2	CRICKN1	E	P	M	C
	D1	D2							
LS66361254QU	12,54	12,54			31,34	E1/LS52201254	LS5219QUASP6	M1/LS66411254	C5/LS52181254
LS6636132-4	13,32	13,32			35	E1/LS5220AA0	P2/LS5219QUASP	M1/LS66411324	C5/LS5218132
LS66361425QU	14,25	14,25			40	E1/LS52201425	P2/LS5219QUASP	M1/LS66411425	C5/LS52181425QU
LS6635QUA	15,85	15,85			49	E1/LS5220AA3	P2/LS5219QUASP	M1/LS6640QUA	C5/LS5218QUASP
LS6635QUA445	15,85	15,85			49	E1/LS5220AA3	P3/LS5246	M1/LS6640QUA445	C5/LS52561585
LS5216164522	16,45*	22,80			85	E1/LS5220A14	P2/LS5219QUA	M1/LS5217164522	C2/LS5218QUA
LS5216171	17,10	17,10			54,4	E1/LS5220171	P2/LS5219QUA	M1/LS5217171	C2/LS5218171
LS5216175QU	17,50	17,50			70	E1/LS5220A10	P2/LS5219QUA	M1/LS5217175QU	C2/LS5218175Q
LS663517QC14	17,74	17,74			60	E1/LS5220177342	P2/LS5219QUA	M1/LS521717QC14	C5/LS521817QC14
LS6635177344	17,74	17,74			60	E1/LS5220AA6	P2/LS5219QUA	M1/LS5217177344	C2/LS5218177344
LS663517734	17,74	17,74			60	E1/LS5220AA6	P3/LS5246	M1/LS521717734	LS521817734
LS6635177341	17,74	36,00			60	E1/LS5220AA6	P3/LS5246	M1/LS5217177341	C2/LS5256
LS6635177342	17,74	36,00			60	E1/LS5220177342	P3/LS5246	M1/LS5217177341	C2/LS5256
LS52161883QU	18,83	18,83			74,5	E1/LS52201883	P2/LS5219QUA	M1/LS52171883QU	C2/LS52181883QU
LS5216189	18,90	18,90			75	E1/LS5220189	P2/LS5219QUA	M1/LS5218189	C2/LS5218189
LS68691902QU	19,02	19,02			69	E1/LS68721902	P2/LS5219QUASP	M10/LS68701902QU	C5/LS68711902QU
LS68691902Q1	19,02	19,02			69	E1/LS68721902	P2/LS5219QUA	M1/LS52171902	C2/LS52181902
LS68691902Q2	19,02	19,02			69	E1/LS5220AA1	P2/LS5219QUA	M1/LS52171902Q2	C2/LS52181902Q2
LS5216193	19,02	31,50			69	E1/LS5220AA1	P3/LS5246	M1/LS5217193	C2/LS0817
LS5216194	19,02	36,00			69	E1/LS5220AA1	P3/LS5246	M1/LS5217194	C2/LS5256
LS52161904Z	19,04Z	19,04Z			79,78	E1/LS52201904Z	P2/LS5219QUA	M1/LS52171904Z	C2/LS52181904Z
LS6869QUA44	19,38	19,38			71	E1/LS6872	P3/LS5246	M1/LS6870QUA44	C2/LS6871QUA44
LS52161938QU	19,38	19,38			71	E1/LS52201938	P2/LS5219QUA	M1/LS52171938QU	C2/LS52181938QU
LS6869228QUA	19,38	22,80			71	E1/LS6872	P2/LS5219QUA	M1/LS6870228QUA	C2/LS5218QUA
LS5216193826	19,38	26,10			71	E1/LS52201938	P3/LS5246	M1/LS5217193826	C2/LS5218261
LS686936	19,38	36,00			71	E1/LS6872	P3/LS5246	M1/LS687036	C2/LS5256
LS5216193836	19,38	36,00			71	E1/LS52201938	P3/LS5246	M1/LS52171938	C2/LS5256
LS521619634	19,60	19,60			86	E1/LS5220196	P3/LS5219QUA	M1/LS6870196-2	C5/LS521819634
LS0820196	19,60	19,60			86	E1/LS5220196	P3/LS5246	M1/LS6870196-1	C5/LS5218196
LS5216202QUA	20,27	20,27			78	E1/LS5220A11	P2/LS5219QUA	M1/LS5217202QUA	C2/LS5218202QUA
LS5216207QUA	20,70	20,70			76,5	E1/LS5220207	P2/LS5219QUA	M1/LS5217207QUA	C2/LS5218207QUA
LS521621QUA	21,00	21,00			99	E1/LS5220AA7	P2/LS5219QUA	M1/LS521721QUA	C2/LS521821QUA
LS082021	21,00	21,00			99	E1/LS5220AA7	P3/LS5246	M1/LS521721-1	C5/LS521821
LS082021315	21,00	31,50			99	E1/LS5220AA7	P3/LS5246	M1/LS521721315	C2/LS0817
LS5216216QUA	21,66	21,66			89	E1/LS5220AA5	P2/LS5219QUA	M1/LS5217216QUA	C2/LS5218216QUA
LS52162226CB	22,26	22,26	LION	LION	100	E1/LS5220A9	P2/LS52192226	M1/LS52162226BI	C2/LS5218300

** = leggendario

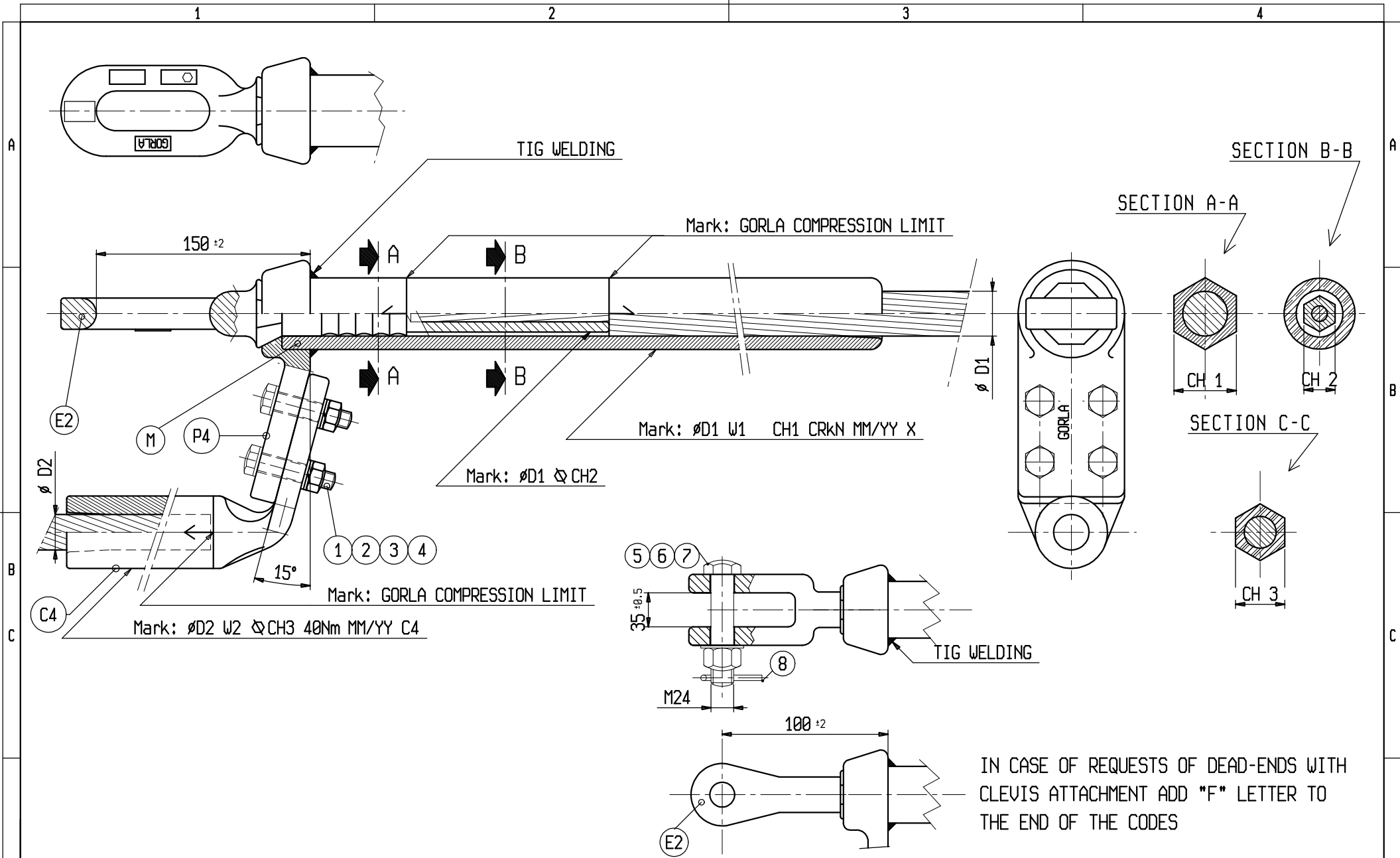

Material. E2, 5, 6 and 7: hot dip galvanised steel
 C4, M e P4: aluminium alloy
 1, 2, 3 e 4: hot dip galvanised or stainless steel
 8: stainless steel

s.r.l. GORLA
 MORSETTERIE
 MILANO
 TECHNICAL OFFICE

COMPRESSION DEAD-END
 CLAMPS
 FOR ACSR CONDUCTORS
 WITH 4 BOLTS

Rev. 3 del 15.11.16

DRG. N. AT01-4-D/X

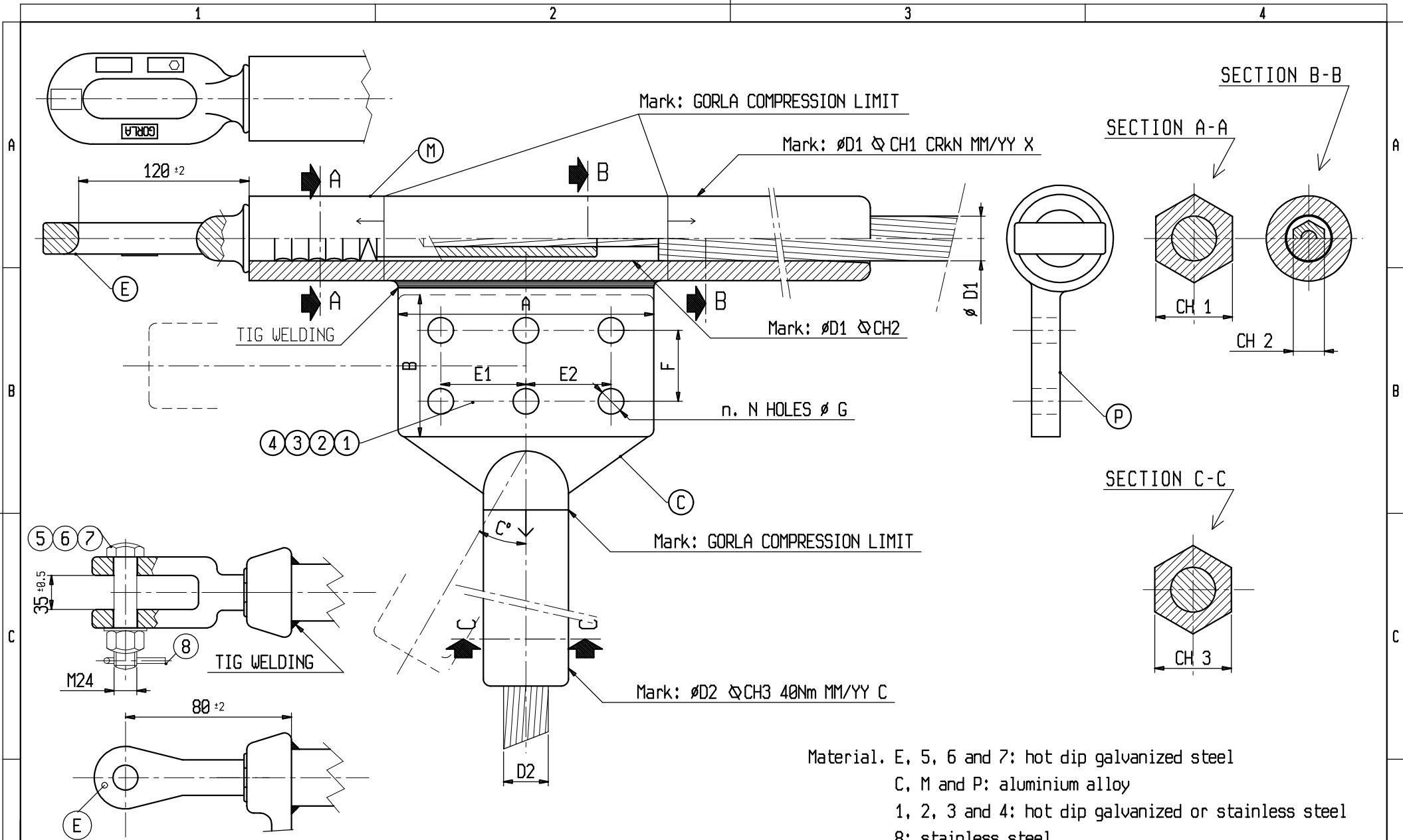

IN CASE OF REQUESTS OF DEAD-ENDS WITH CLEVIS ATTACHMENT ADD "F" LETTER TO THE END OF THE CODES

Material. E, 5, 6 and 7: hot dip galvanized steel
 C, M and P: aluminium alloy
 1, 2, 3 and 4: hot dip galvanized or stainless steel
 8: stainless steel

<p>s.r.l. GORLA MORSETTERIE MILANO TECHNICAL OFFICE</p>	<p>COMPRESSION DEAD-END CLAMPS FOR ACSR AND HTLS CONDUCTORS WITH LONGITUDINAL JUMPER</p>	<p>Rev.3 dated 14.03.19 DRG. N. AT01-AL/X</p>
--	--	--

